



Fab Shop/Paint Weld Assembly Purchasing
Freight Y/N

REQUEST FOR SPECIAL QUOTE

Date: _____

Company Requesting: _____

New Quote

Contact: _____

Quoted Before, Quote # _____

Phone: _____ Fax: _____

Ordered Before, PO # _____

Email: _____ Dutro Assigned Pt. # _____

Quantity _____ Color _____ Used for _____

Drawing – Sketch – Picture attached **Required** Dutro Generic _____ Customer _____

Basic description: _____

Overall distributed capacity required: _____

Please list any critical clearances needed (i.e. for doorways, elevators, scales, etc). _____

Tolerance: _____

Please mark as needed:

Disclaimer: If not specified, Dutro will select default.

Handle

- Permanent Removable N/A
- Swivel End Rigid End N/A

Shelf How Many? _____ Capacity Per Shelf? _____

- Lips Up Lips Down

CUSTOMER TO APPROVE
DRAWINGS YES__ NO__

Sent to customer _____

Back from customer _____

Casters

Furnished by: Dutro Customer

- Rigid _____ Swivel _____
- Bolt on Weld on

If furnished by customer, who installs?

- Dutro install Ship as frame

Caster Plate size: _____

Bolt Pattern: _____

Caster Overall Height: _____

Wheels

Furnished by: Dutro Customer

Size _____ Mold on Rubber Pneumatic Solid Rubber Balloon Poly Flat Free

Diameter _____ Bearing size _____ Hub Length _____

Please attach additional instructions as necessary.

HAND TRUCK

OVERALL HEIGHT

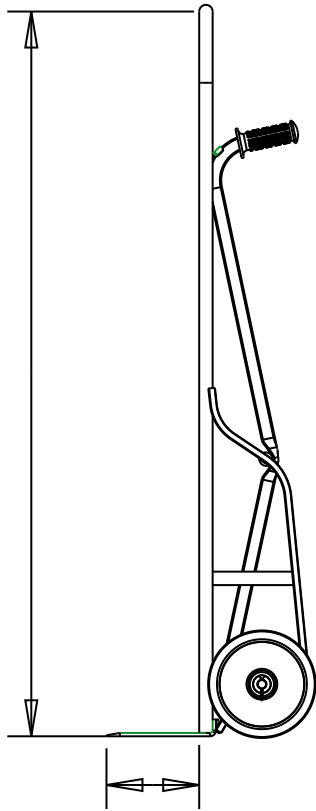

FRAME WIDTH

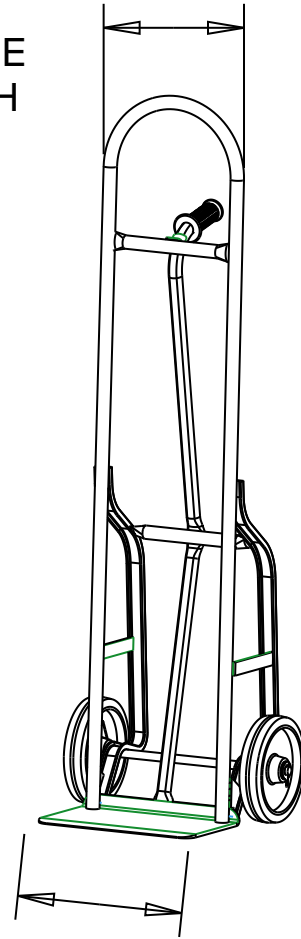

WHEEL DIAMETER

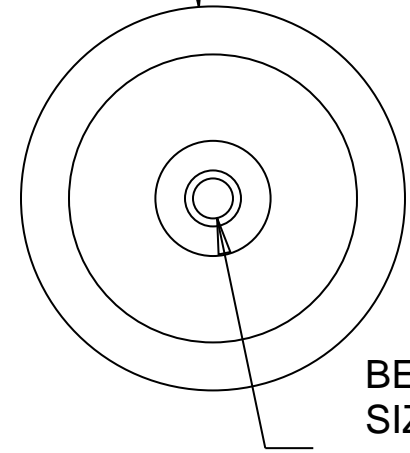

BEARING SIZE

USEABLE (CLEAR) TOE PLATE LENGTH

TOE PLATE WIDTH

HUB LENGTH

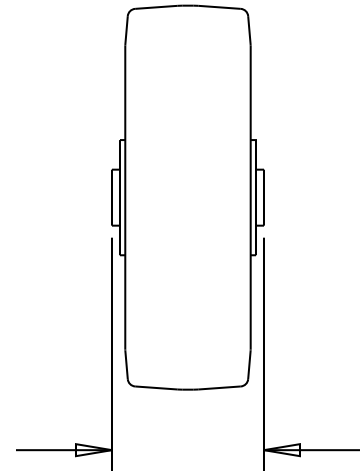

CUSTOMER NAME	
CRITICAL DIMENSIONS	
TOLERANCES	
CAPACITY DISTRIBUTED	

CART

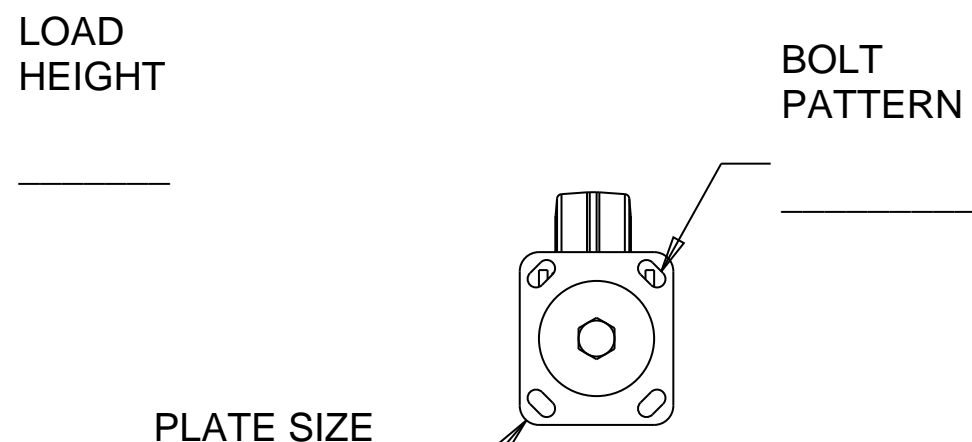
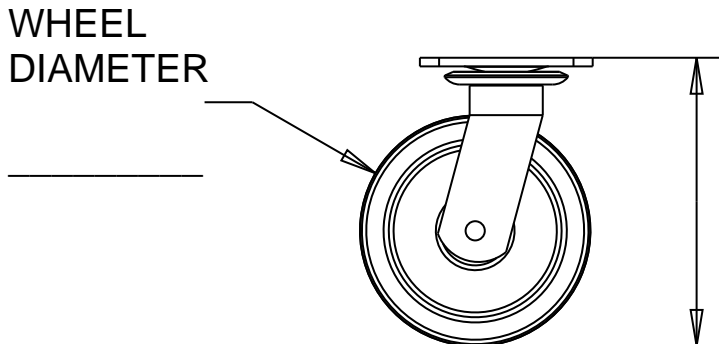
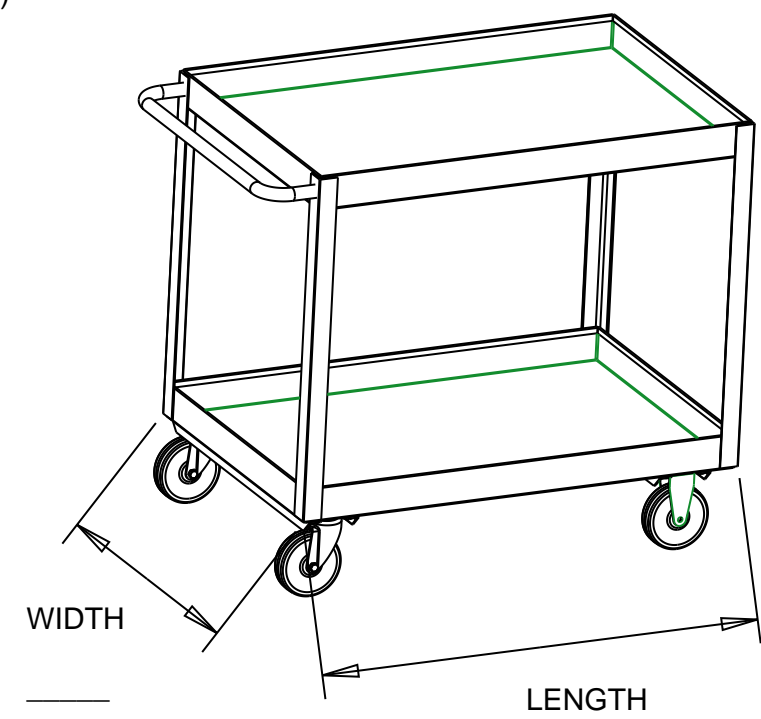
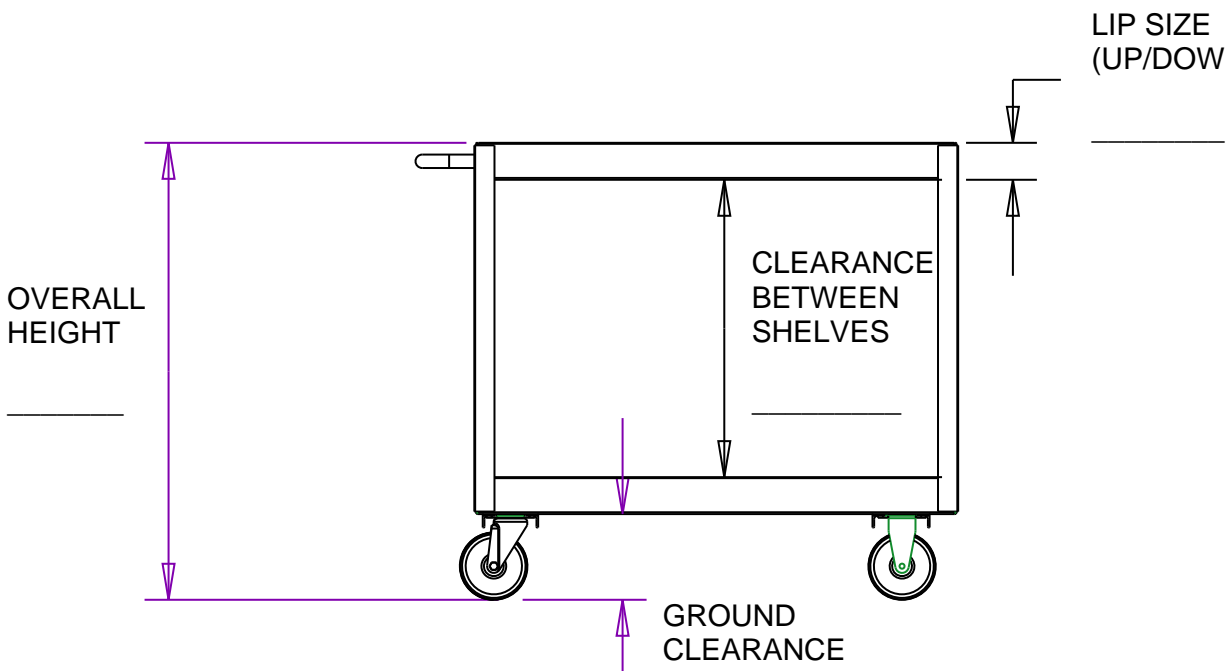

CUSTOMER NAME	
CRITICAL DIMENSIONS	
TOLERANCES	
CAPACITY DISTRIBUTED	

MATRESS CART

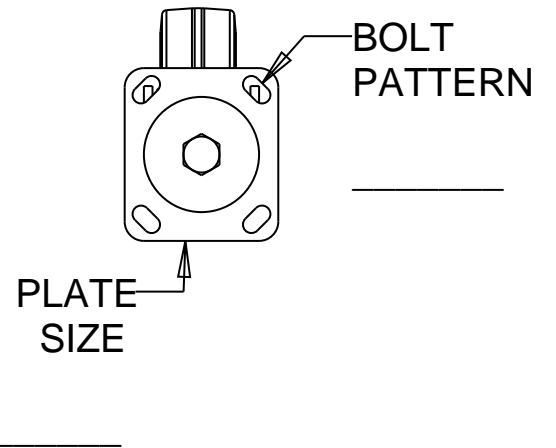
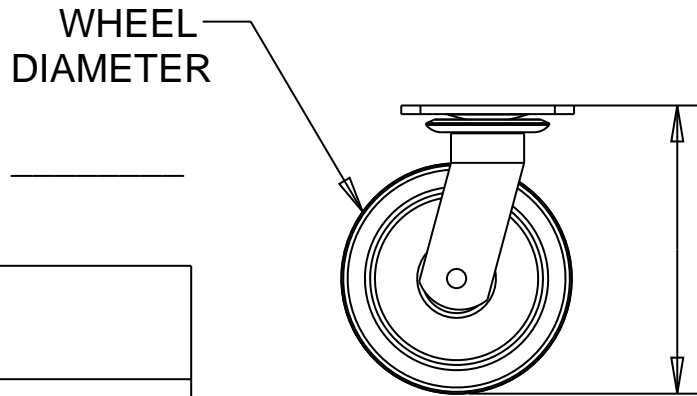
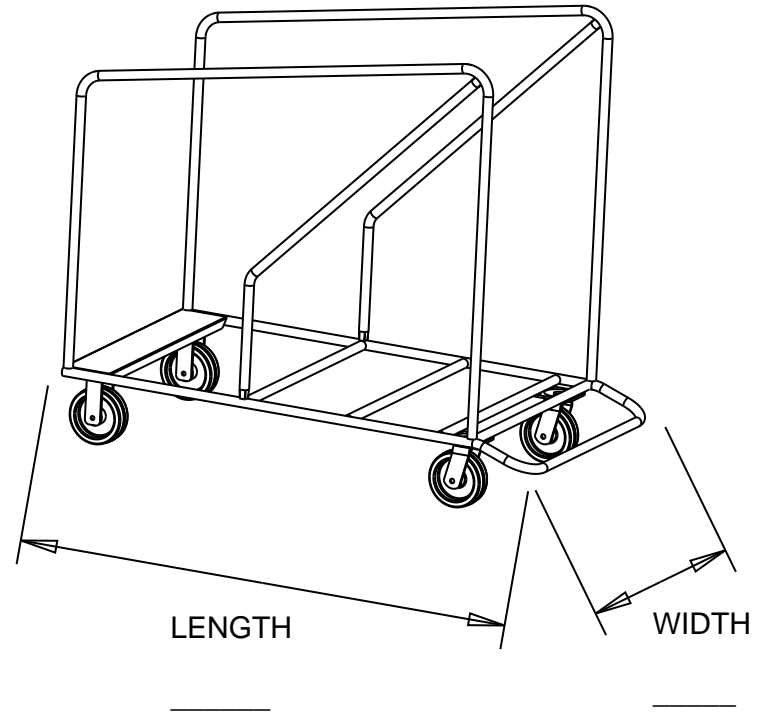
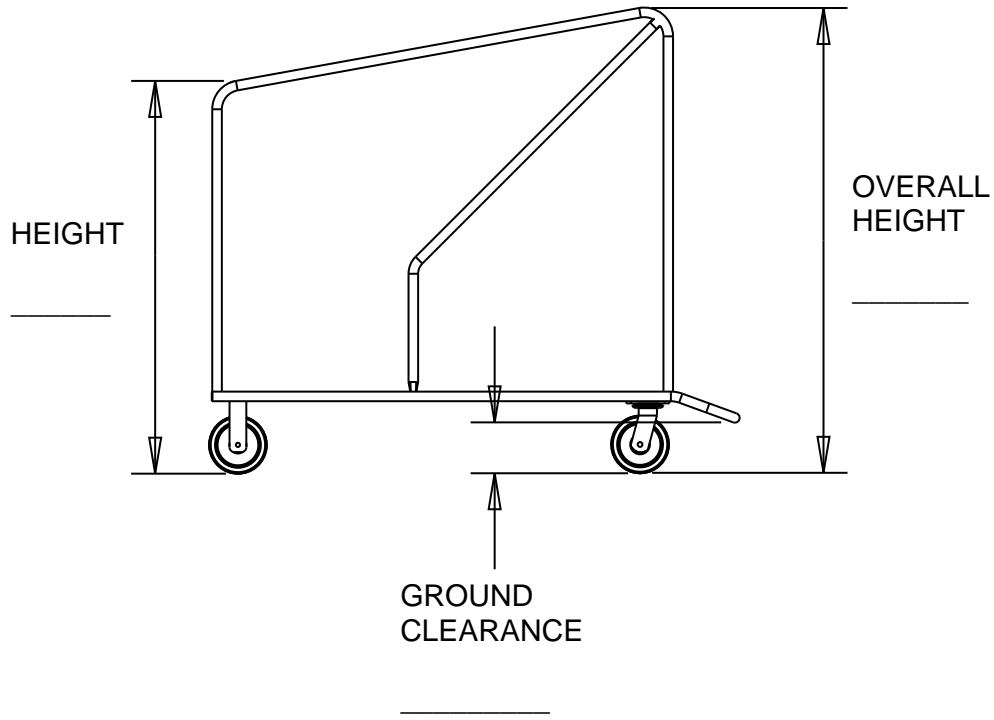

CUSTOMER NAME	
CRITICAL DIMENSIONS	
TOLERANCES	
CAPACITY DISTRIBUTED	

PLATFORM TRUCK

REMOVABLE HANDLE YES / NO

OVERALL HEIGHT

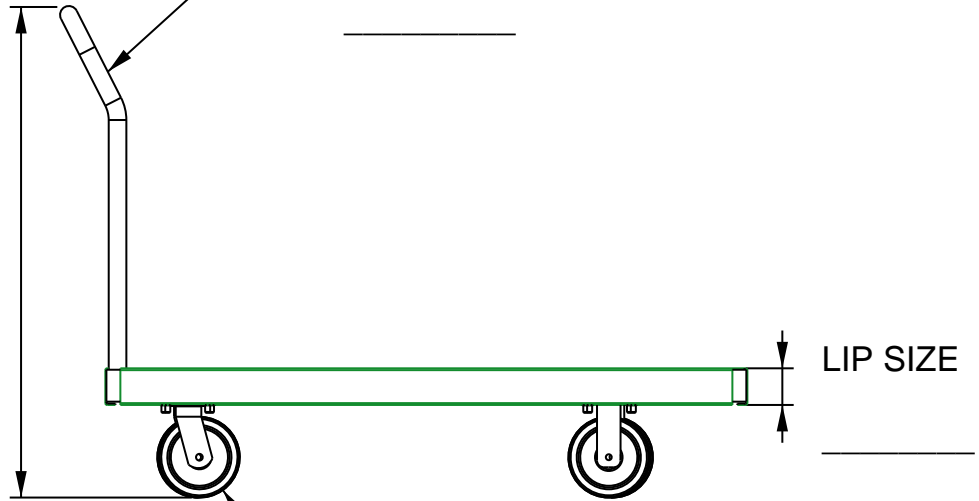

CASTER WHEEL SIZE

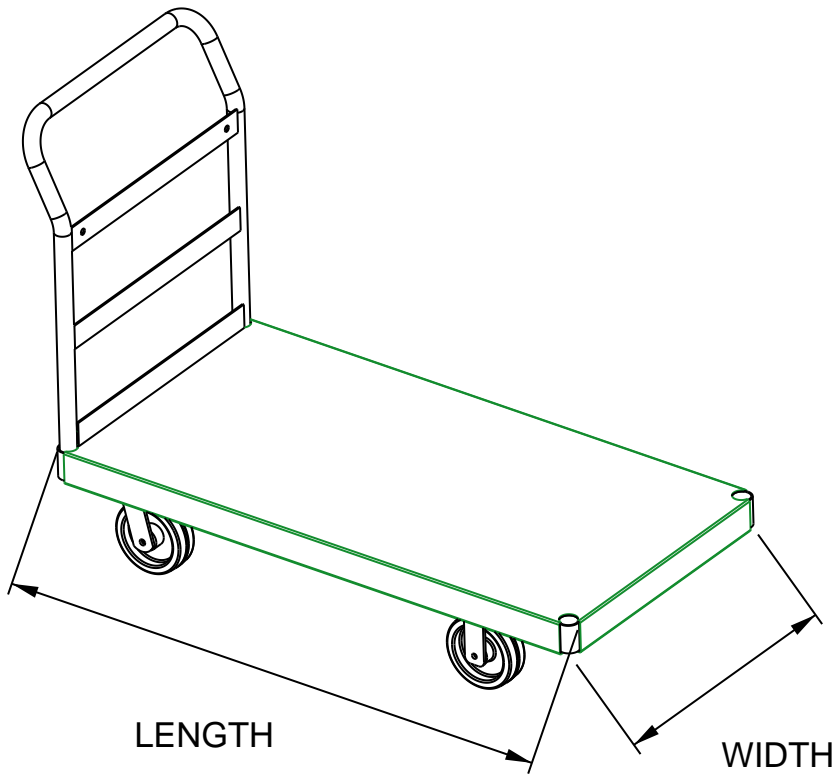

LENGTH

WIDTH

WHEEL DIAMETER

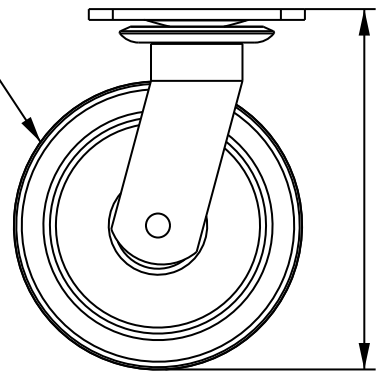

LOAD HEIGHT

PLATE SIZE

BOLT PATTERN

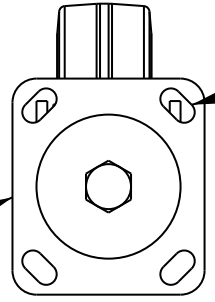

CUSTOMER NAME	_____
CRITICAL DIMENSIONS	_____
TOLERANCES	_____
CAPACITY DISTRIBUTED	_____

STOCKING CART

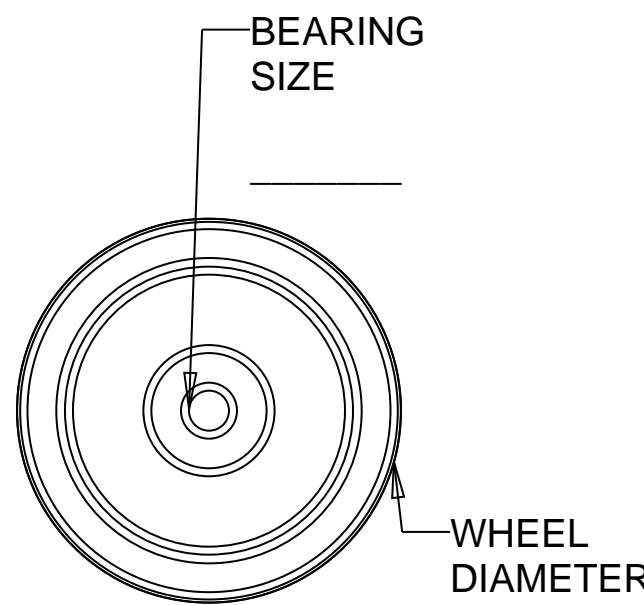
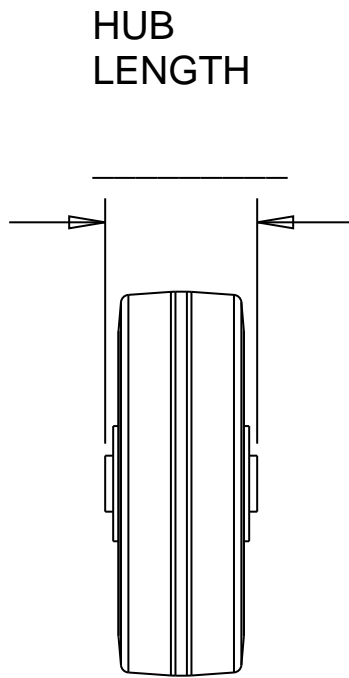
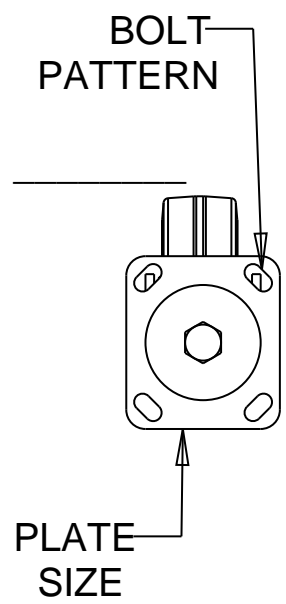
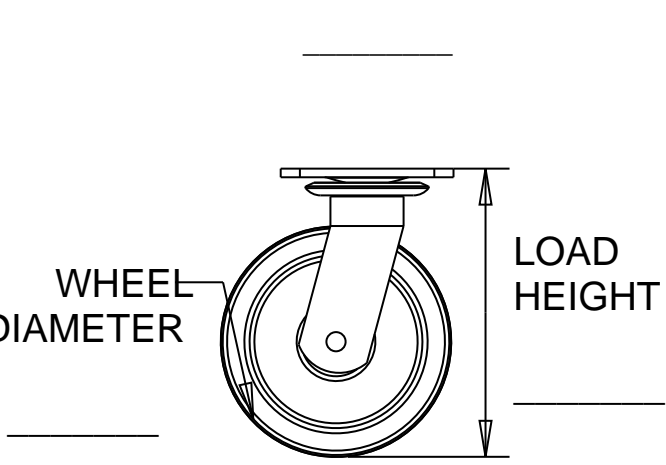
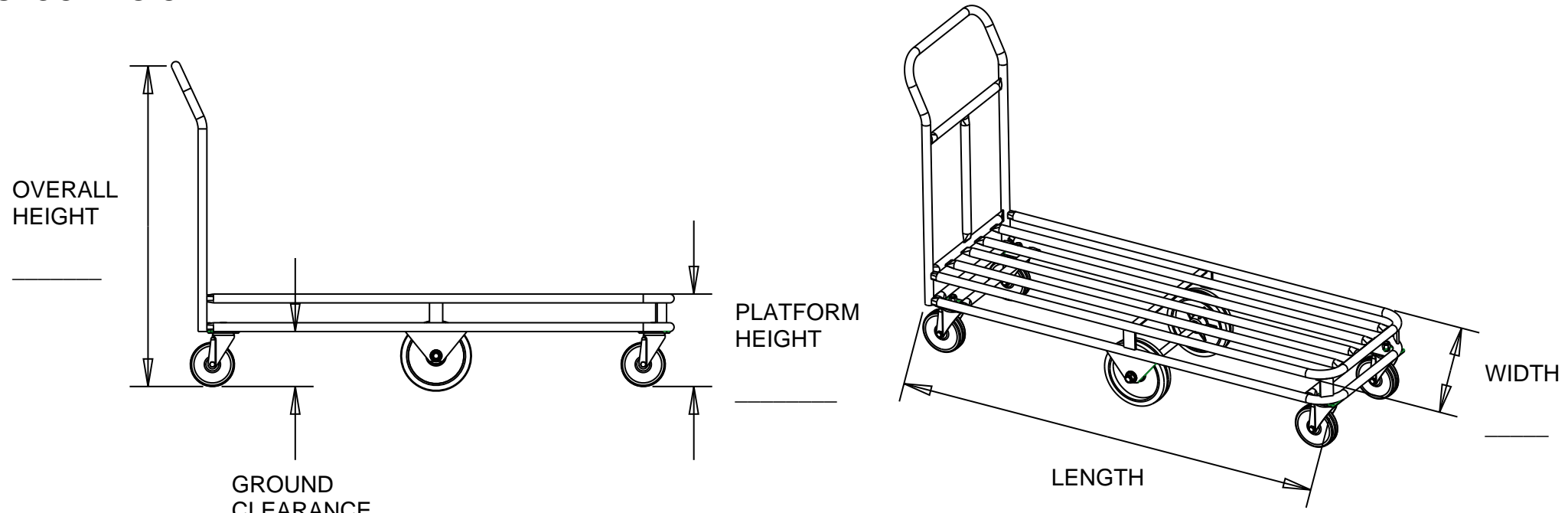

CUSTOMER NAME	
CRITICAL DIMENSIONS	
TOLERANCES	
CAPACITY DISTRIBUTED	